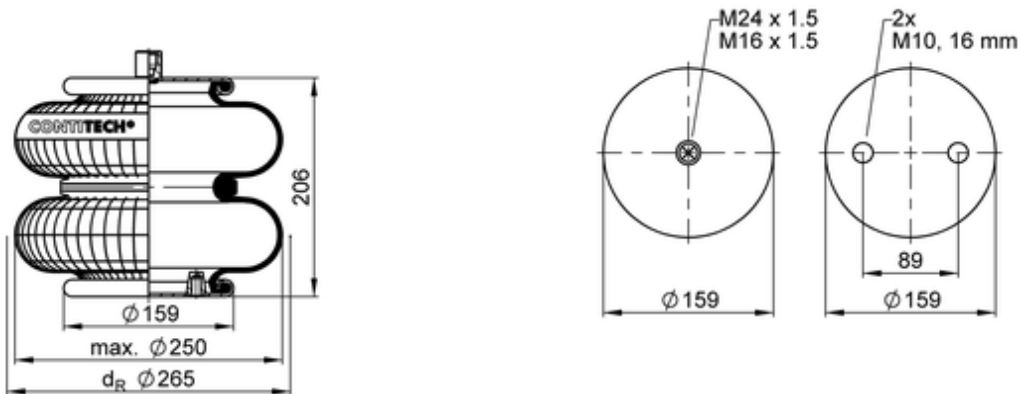

FD 200-19 P02
72043

bolt or stud
 hole
 combination stud
 air inlet
 stud and nut

	2,8 kg
	10002630
	M10: max. 35 Nm
	M24x1.5: max. 100 Nm

OE Manufacturer/Part No.

Manufacturer	Original Part No.	Model
Mercedes	A 942 320 58 21	
Mercedes	A 942 327 08 01	
Mercedes	A 942 320 60 21	
Mercedes	A 942 327 06 01	Hendrickson MLA1
Hendrickson	HS505613	MLA1
Hendrickson	HS507487	Scania appl.
Hendrickson	HS506118	MB appl. MLA1, Voss 230
Hendrickson	HS508264	MB appl. MLA2, MLA2+, Voss 232

