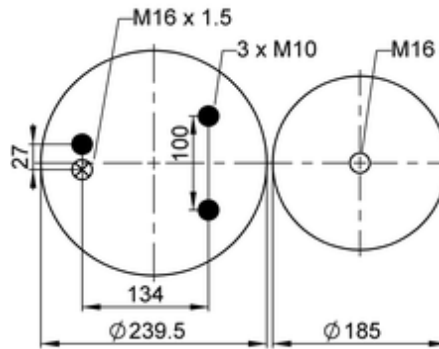
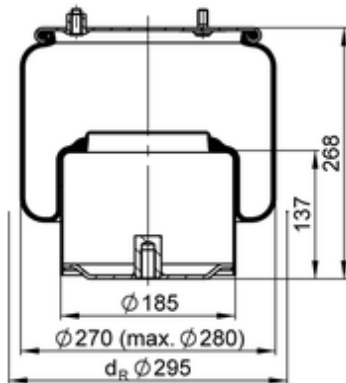

887 M K4
60218

- bolt or stud
- hole
- combination stud
- air inlet
- stud and nut

kg	5,9 kg
	K008
	M10: max. 35 Nm
	M16: max. 130 Nm
	M16x1.5: max. 40 Nm

OE Manufacturer/Part No.

Manufacturer	Original Part No.	Model
DAF	1 529 837	
DAF	1 286 251	
DAF	1 697 680	CF 65
DAF	1 697 680	CF 75-85
DAF	1 697 680	LF 45-55

DAF

1 697 680

XF 95-105