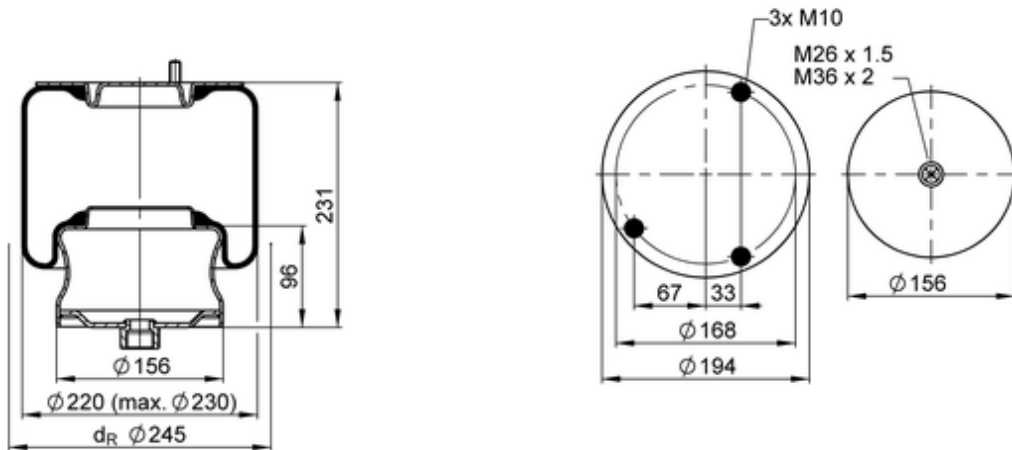

**819 N P01**
**70279**

bolt or stud   
  hole   
 ⊗ combination stud   
 ⊗ air inlet   
 ● stud and nut

	4,1 kg
	M10: max. 35 Nm
	M36x2: max. 100 Nm

**OE Manufacturer/Part No.**

Manufacturer	Original Part No.	Model
Mercedes	667 328 00 01	
Paul NFZ	P29P08320080	Transporter
Mercedes	A 667 328 00 01	Vario