

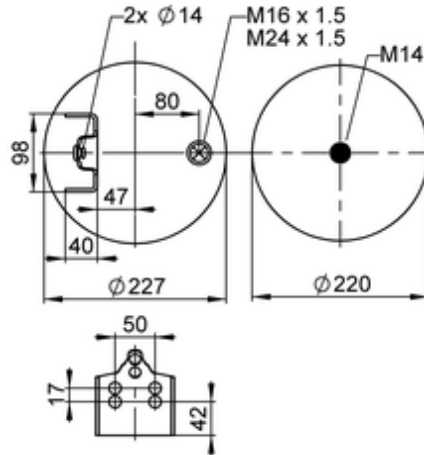

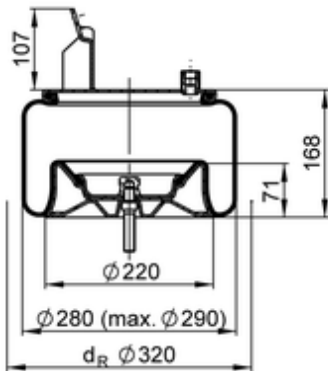







6614 N P01

70545



 bolt or stud
  hole
  combination stud
  air inlet
  stud and nut

	6,6 kg
	
	M14: max. 120 Nm
	M16x1.5: max. 20 Nm
	M24x1.5: max. 60 Nm

OE Manufacturer/Part No.

Manufacturer	Original Part No.	Model
Volvo	20 737 943	
Volvo	20 424 543	
Volvo	20 737 947	FM / FH Xlow
Volvo	21 961 458	FM / FH Xlow
Volvo	20 583 420	FM / FH Xlow

