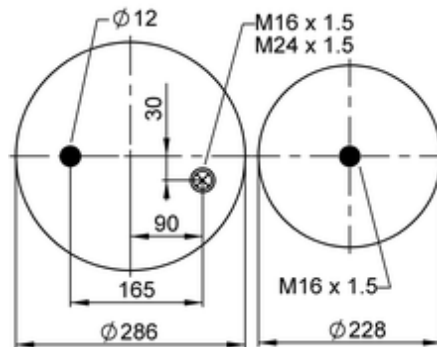
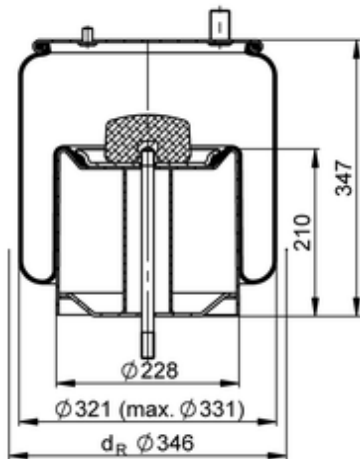

4911 N P06
67741

- bolt or stud
- hole
- combination stud
- air inlet
- stud and nut

	13,6 kg
	10086796
	K018
	M16x1.5: max. 180 Nm
	M16x1.5: max. 80 Nm
	M24x1.5: max. 120 Nm

OE Manufacturer/Part No.

Manufacturer	Original Part No.	Model
Renault	5.010.600.439	Premium / Magnum low
Renault	7.421.978.495	Premium / Magnum low
Renault	5.010.305.464	Premium / Magnum low
Renault	7.425.372.810	Premium / Magnum low

Volvo	21 978 502	FM / FH low
Volvo	20 726 769	FM / FH low