

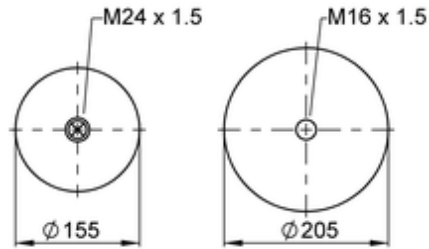

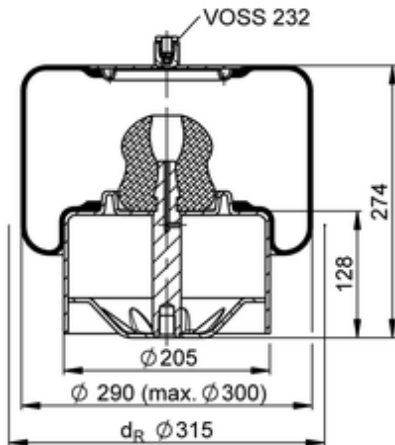









4644 N P22

74008



 bolt or stud
  hole
  combination stud
  air inlet
  stud and nut

	8,3 kg
	4644 N P02
	10086943
	
	M16x1.5: max. 130 Nm
	M24x1.5: max. 100 Nm

OE Manufacturer/Part No.

Manufacturer	Original Part No.	Model
EvoBus	629 320 00 25	
EvoBus	A 629 320 00 25	O 540
EvoBus	A 629 320 00 25	O 580
EvoBus	A 629 320 00 25	OC 500 IBC (≥2008)
EvoBus	A 629 320 00 25	OC 500 IBC (<2008)

EvoBus	A 629 320 00 25	TC 400
EvoBus	A 629 320 00 25	Tourismo / Travego (<2008)
EvoBus	A 629 320 00 25	Tourismo/Travego (≥2008)